

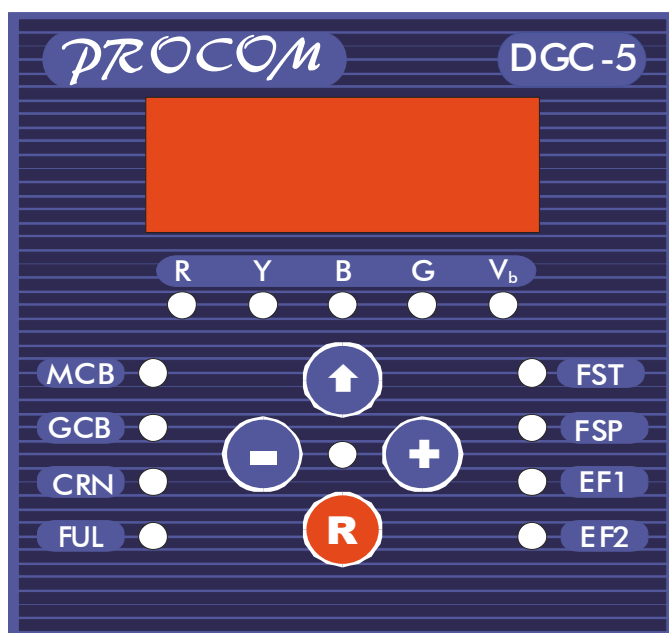

OPERATING INSTRUCTION: DGC-5



MRM **PROCOM** Pvt Ltd

Corporate office:

238, Sukhdev Vihar, New Delhi -110025

Ph: 26913223

Works:

E 41/5 , Okhla Industrial Area, Phase II, New Delhi -110020

Ph: 011-30883537-39, 9313213223, 9810388177 Fax: 011-30883536

Email: mrmprocom@rediffmail.com

Index

- 1.1 Introduction
- 1.2 Salient Feature of the DGC-5
 - 1.2.1 Protection & Supervision
 - 1.2.2 Measurement & Display
 - 1.2.3 LED Indications
 - 1.2.4 Timer
- 1.3 Function
- 1.4 Engine solenoid
- 1.5 Terminal No. 9.
- 1.6 Display
- 1.7 Programming Mode
 - 1.7.1 Setting Table
- 1.8 Annunciation LED Functions
- 1.9 Switch Description
- 1.10 Fault
 - 1.10.1 Internal Fault
 - 1.10.2 External Fault
 - 1.10.3 Fault Reset
- 1.11 Specification
- 1.12 Connection Diagram
- 1.13 Model Selection

DGC-5

Automatic Engine Controller

1.1 Introduction

- The Microprocessor / microcontroller based DGC-5 automatic generator start and supervisory device is designed keeping in view the ease of operation.
- Housed in 96 x 96 flush mounted enclosure, is an ideal replacement of logic based AMF.
- The functions of the discrete logic based AMF units are built in to the one single compact device, resulting in simplified panel wiring and size reduction.

1.2 Salient features of the DGC-5

1.2.1 Protection & Supervision:

- 3 phase Under & Over voltage protection for EB supply (True RMS measurement)
- Phase under & over voltage protection of Generator supply(True RMS measurement)
- User programmable Cranking attempt.
- Generator over speed supervision
- DC Battery Voltage supervision (Under & Over voltage)
- External fault detection (2 digital inputs)
- External engine running signal
- DG Fail to start supervision and indication
- DG fail to stop supervision and indication
- Unit remains fully operational even if battery voltage falls to zero volts for one sec.

1.2.2 Measurement & Display.

DGC-5, equipped with four seven segment display, displays:

- EB voltages of RYB phase
- Generator voltage
- DC battery voltage
- Generator frequency
- Set values

1.2.3 LED Indication

- Status Indication of mains supply (R,Y,B)
- Status Indication of generator voltage (G)
- Status indication of battery voltage (Vb)
- Generator frequency
- Load on generator (GON)
- Load on EB (MON)
- Cranking ON (CRN)

- Fuel Solenoid On (FUL)
- DG Fail to start (FST)
- DG Fail to stop (FSP)
- External fault 1 (EF1)
- External fault 2 (EF2)

1.2.4 *Timers*

Following timers are incorporated in the DGC-5

- DG Start delay (variable)
- Generator Voltage Supervision (variable)
- Max. cranking time (variable)
- Crank gap time (variable)
- No of crank attempts (variable)
- Mains restoration time (variable)
- DG recooling time (variable)
- External fault delay timer (2-variable)
- Hooter reset time (fixed)
- Generator over speed delay timer (Variable)
- Timer for stop solenoid (Variable)

1.3 *Function:*

DGC-5 monitors the Mains supply, if Mains supply varies beyond set limit of under and over voltage for more than Mains restoration time, DGC-5 starts the genset.

To start the genset DGC-5 gives a cranking signal via potential free contact to starting motor, Crank command is withdrawn if it is detected that the engine has started either by external engine start input or by build up of generator voltage.

Max duration of crank command is user settable.

The maximum number of cranks are user programmable and if the genset fails to start after the maximum programmed crank attempts are issued, FST LED starts blinking indicating fail to start fault and the hooter is switched on.

While the genset is running DGC-5 monitors the genset for external fault EF1, EF2 and voltage healthiness.

On detection of any fault, genset is stopped by the DGC-5, after set time delay & hooter is switched on.

On restoration of healthy EB supply for the set time duration the genset is stopped after recooling it for the user set recooling time.

Load changeover is done automatically by DGC-5.

1.4 **Engine solenoid:** Engine solenoid contact (Terminal 15 & 16) can be configured in two modes

- Mode 0:** In this mode fuel solenoid contact changes from NO to close at the time of cranking and remains close till the genset is running . For stopping the generator this contact opens.

- b. Mode 1:** In this mode fuel solenoid contact remains open at the time of cranking and till the genset is running . For stopping the generator this contact closes for a user programmed time.

For changing the solenoid mode first press © (reset) button, than simultaneously press +ve and –ve button while the reset button is pressed. The 4th Display digit shall display “t”. Don’t change the mode while generator is running. It’s a good practice to switch off and than switch on the battery supply after changing the mode.

1.5 Terminal No. 9.

DGC-5 uses this pin to sense the running of the generator. Logical low on this pin indicates that the engine has started and the crank is discontinued.

In DGC-5M this pin is used to put the relay in manual mode. A logical low on this pin will enable the manual mode. In this mode DGC-5M shall release the control of all the output contacts except fuel and hooter. The engine can be manually started/stopped and load manually transferred to mains or generator. The external faults , EF1 & EF2 shall be supervised by the DGC-5M and in case of fault it shall shut down the engine by activating /de activating fuel solenoid and activate the hooter. All meter functions shall also be available in this mode. There is no need to switch off the power of the unit to enter the manual mode.

1.6 Display:

It has 4 Seven Segment bright LED display, to display voltages. Beside the numeric display there are 14 LEDs for annunciations as shown below.

The right most 3 digits are in normal use and they display the following:

- a) AC Voltage of mains R, Y, B (Phase to neutral), Generator voltage (Phase to neutral)
- b) Generator frequency
- c) Battery Voltage

The 4th digit (left most) is used during the parameter programming mode to indicate the parameter being programmed.

1.7 Programming mode:

Programming mode can be entered any time by simultaneously pressing + & ■ keys. While in program mode, the 4th digit (left most) shall have a digit indicating the parameter under programming. The following table details the various programmable parameters:

1.7.1 Setting table

Sl. No	Display on 4 th Digit	Parameter	Explanation of parameter	Factory setting	Setting Range
1	1	Mains Over Voltage	Max. Permissible voltage, above this the voltage is treated unhealthy & Genset is started.	270V	80-270V
2	2	Mains Under Voltage	Min. permissible voltage, below this the voltage is treated unhealthy & Genset is started	180V	80-270V
3	3	Mains voltage supervision time	Time for which the mains voltage has to be unhealthy (under or over voltage as defined above in 1 & 2) before starting the generator.	5Sec	0-999Sec
4	4	Generator Over Voltage	Max. Permissible voltage, above this the voltage is treated unhealthy & the generator is stopped by releasing fuel solenoid. Generator contactor is released and mains contactor is closed. Hooter shall be activated and generator voltage LED (Vg) shall start flashing.	270V	80-270V
5	5	Generator Under Voltage	Min. permissible voltage, below this the voltage is treated unhealthy & the generator is stopped by releasing fuel solenoid. Generator contactor is released and mains contactor is closed. Hooter shall be activated and generator voltage LED (Vg) shall start flashing	180V	80-270V
6	6	Generator Unhealthy Time	The time for which the generator voltage should, continuously be unhealthy to generate a fault condition.	10Sec	0-999 Sec.
7	7	No. of Crank Attempt	The maximum number of crank that shall be issued to start the generator	3	1-10
8	8	Crank Time	Maximum crank time	10Sec	0-25Sec
9	9	Crank Delay	The delay between two successive cranks	5	1-100Sec
10	A	Change over delay	The load is transferred to Genset after the programmed time	1	0-100Sec
11	b	Mains Restoration Time	The time for which mains should be continuously healthy before stopping the generator.	30Sec	0-999Sec
12	C	Generator Recooling Time	The time for which generator is allowed to run on no load before switching off	30 sec	0-999Sec
13	D	External fault 1 Time	Time delay before this fault can be activated.	5 Sec	0-999Sec

		delay	Faults are described in details.		
14	E	External fault 2 Time delay	Time delay before this fault can be activated. Faults are described in details.	5 Sec	0-999Sec
15	F	DC System Voltage	Set DC System Voltage	12V	12/24 V
16	H	Over speed Frequency	The maximum generator voltage frequency beyond which over speed is detected	65	40-80
17	L	Over speed delay	Time for which over speeding is allowed	30Sec	0-999Sec
18	P	Stop solenoid time	The time for which stop solenoid will be kept active while stopping the engine	30Sec	0-100Sec

1.8 Annunciations LED's Functions:

S, No.	LED Nomenclature	Description
1	MON	This LED lights up when the mains circuit is closed and the power is feed to the load by mains supply
2	GON	This LED lights up when the Generator circuit is closed and the power is feed to the load by Generator
3	CRK	This LED is on when the generator is being cranked.
4	Fuel	This LED is on while the Fuel Solenoid is active
5	R	ON: Indicated that the displayed value is R Phase voltage of main supply FLASHING: The mains R Phase voltage is outside the defined limits.
6	Y	ON: Indicated that the displayed value is Y Phase voltage of main supply FLASHING: The mains Y Phase voltage is outside the defined limits
7	B	ON: Indicated that the displayed value is B Phase voltage of main supply FLASHING: The mains B Phase voltage is outside the defined limits
8	G	ON: Indicated that the displayed value is Generator Phase voltage FLASHING: The Generator Phase voltage is outside the defined limits
9	Vb	System Voltage =1(12V System): The LED Flashes if the battery voltage is <10V or > 15V System Voltage =2(24V system): The LED Flashes if the battery voltage is <18V or > 30V
10	FST	Fail To Start: If the generator does not start even after 3 crank attempts, an alarm is issued and this LED starts blinking indicating a fault. This led also blinks along with G led in case

		of engine fault
11	FSP	Fail To Stop: If the generator does not stop even after 30 seconds of stopping command an alarm is issued and this LED starts blinking indicating a fault
12	EF1	External Fault 1: Blinking LED indicates an fault generated by external signal 1
13	EF2	External Fault 2: Blinking LED indicates an fault generated by external signal 2
14	(In centre of switches)	In version with over speed supervision this led shall light while the generator frequency is being displayed and will blink along with FST led.

1.9 Switches Description:

S.No.	Switch Symbol	Switch Function	Description
1	↑	Next	Normal operation mode: In this mode, next is used to select the voltages on the display. The default voltage is mains R Phase voltage. Y Phase, B Phase, Generator voltage & Battery Voltage can be selected by pressing next. The corresponding LED shall light up to indicate the parameter that is displayed. Programming Mode: Next key is used to select the next parameter to be programmed.
2	+	Increment	This key is only active during programming mode and is used to increment the value of the parameter under programming.
3	-	Decrement	This key is only active during programming mode and is used to decrement the value of the parameter under programming.
4	⊙	Reset	Reset keys resets the Hooter and Fault signals. The first press shall reset the hooter and next shall reset the faults. A long press of 1 Sec shall reset both.
5	+ & -	Programming Mode Entry	If both the keys are pressed simultaneously the unit will enter in programming mode.

1.10 Faults:

There are two categories of faults

- 1) Internal Faults
- 2) External faults

1.10.1 Internal Faults:

Internal faults are the faults, which do not need any external signals and are detected by the system itself. They are:

- i) **Generator Fails to Start.** Corresponding LED blinks and hooter is activated
- ii) **Generator Voltage Unhealthy.** Corresponding LED blinks and hooter is activated
- iii) **Generator Fails to Stop.** Corresponding LED blinks and hooter is activated
- iv) **Over-speed.** Corresponding LED blinks, hooter is activated & Genset stops.
- v) **Battery under or over voltage.** Corresponding LED blinks.

1.10.2 External Faults:

Those faults which cannot be sensed by the unit itself (these faults are not reflected by the generator voltage) and are to be provided externally. The external faults could be Low Lube Oil Pressure, High Water Temperature, emergency stop etc.

There is provision to connect two such faults externally.

- i) **External Fault 1:** This fault can only be activated while the generator is running. If the genset is off because the mains is available or some other fault have switched off the generator this fault shall be inactive.
If this fault gets active in the generator running condition, it shall stop the generator after expiry of programmed "External fault 1 Time delay", switch on the hooter & blink the EF1 LED.
This fault can be used to detect Low Lobe Oil Pressure.
- ii) **External Fault 2:** This fault always remains active irrespective of generator condition (ON or OFF).
This fault is also provided with a variable timer, and is generated after the expiry of programmed "External fault 2 Time delay". This fault can be used for emergency stop or it can be used for high water temperature

110.3 Fault Reset:

- i) **Internal Faults:** All internal faults can be reset by pressing Ⓞ (Reset Key).
- ii) **External Fault 1:** This fault can be reset by pressing Ⓞ (Reset Key).
- iii) **External Fault 2:** This fault cannot be reset till the conditions creating this fault are not cleared. Until this fault is cleared the generator shall not start.
- iv) **Auto Fault Reset:** The internal faults and External Fault 1 shall also automatically get reset when the mains restores and again fails. In case of the conditions which created the faults persists, the fault shall again get activated and stop the generator.

Auto Fault Reset is debarred for External Fault 2 and the conditions creating the fault shall have to be cleared for any further action.

Contacts after the fault conditions: Immediately after any of the faults becomes active the generator is stopped by deactivating the fuel solenoid. The Generator Circuit Breaker contact is released, and after 125millsec delay the load is transferred to mains supply. The hooter is active for 30 second if not reset during this period.

Type of Contacts: All contacts are normally open (NO) type except the Mains Circuit breaker contact which is Normally Closed (NC) type.

1.11

Specifications

AC voltage withstand	330 VAC continuously (Phase to neutral)
Measurement Accuracy	1%
Surge 1.2/50Usec	2.5KV
Battery Voltage	Suitable for 12V/24 VDC System
Max. Battery Voltage	35V
DC Interruption time	1 Sec.
Out Put Contact	5 NO
Contact Rating	230V / 6A
Cut out Dimensions	90mm X 90mm
Depth	120mm
Digital Input Level	Battery Voltage (Negative)

1.12

Connection Diagram

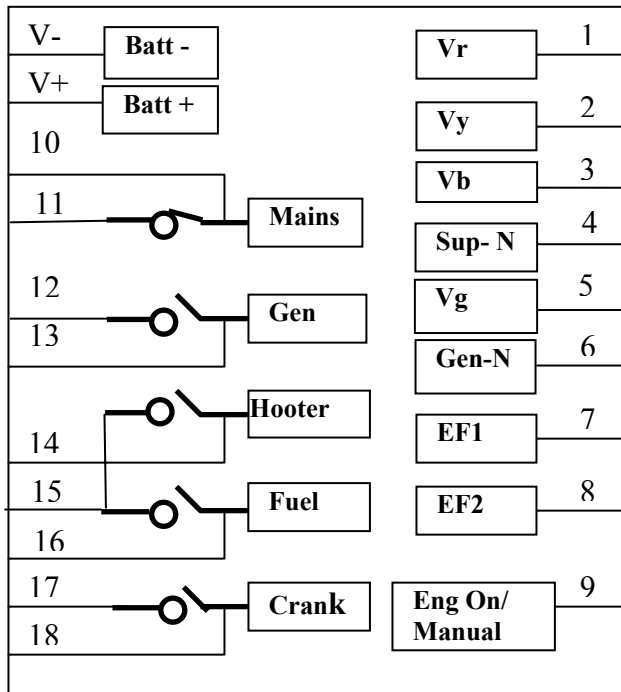

1.14 Model Selection :

- | | |
|---|--------|
| 1. Engine Running Signal by a digital input | DGC-5 |
| 2. Manual Input | DGC-5M |

It is our endeavour to constantly upgrade our products, hence specifications are subject to changes without any notice.